

REF. INSTRUCTION SHEET NO.: 80-0180-367
 ECN NO.: 9629
 TEMPLATE NO.: 52140-1
 DATE: 06-25-97

ADAMS RITE MANUFACTURING COMPANY
 POMONA, CA. 91767
 7170/7270 ELECTRIC STRIKE
 FOR METAL JAMB WITH
 MORTISE LATCHES

ELECTRIC STRIKE DIMENSIONS

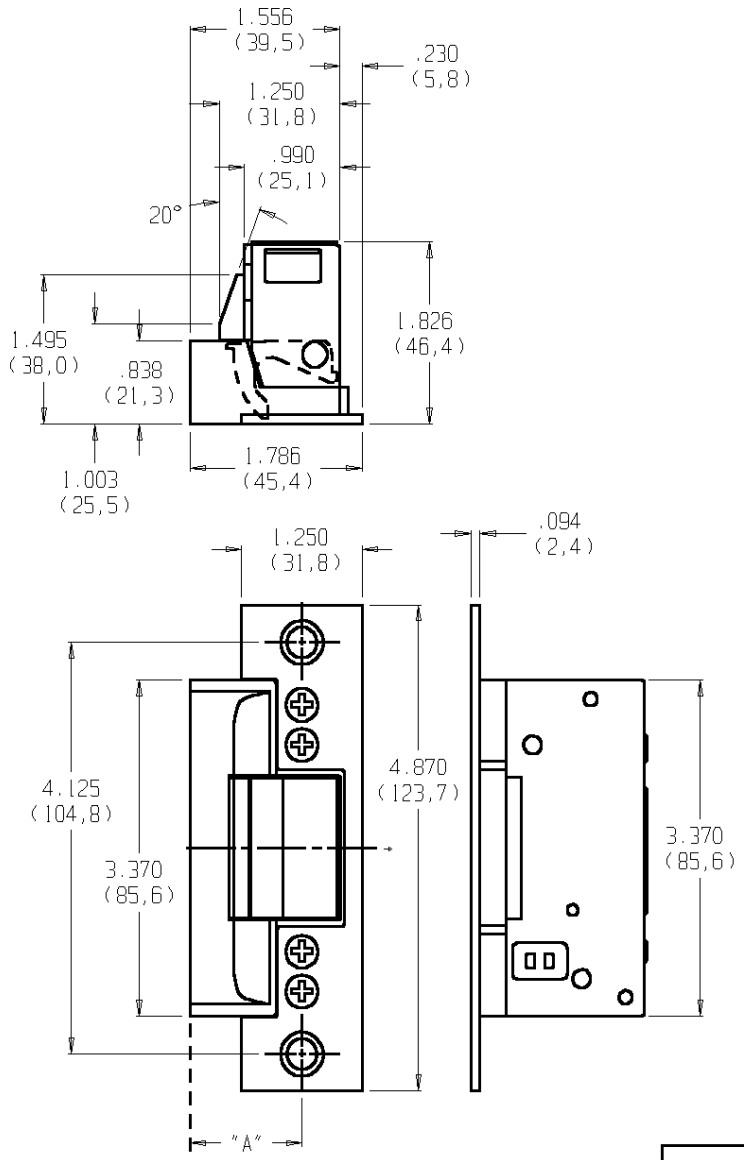

JAMB PREPARATION

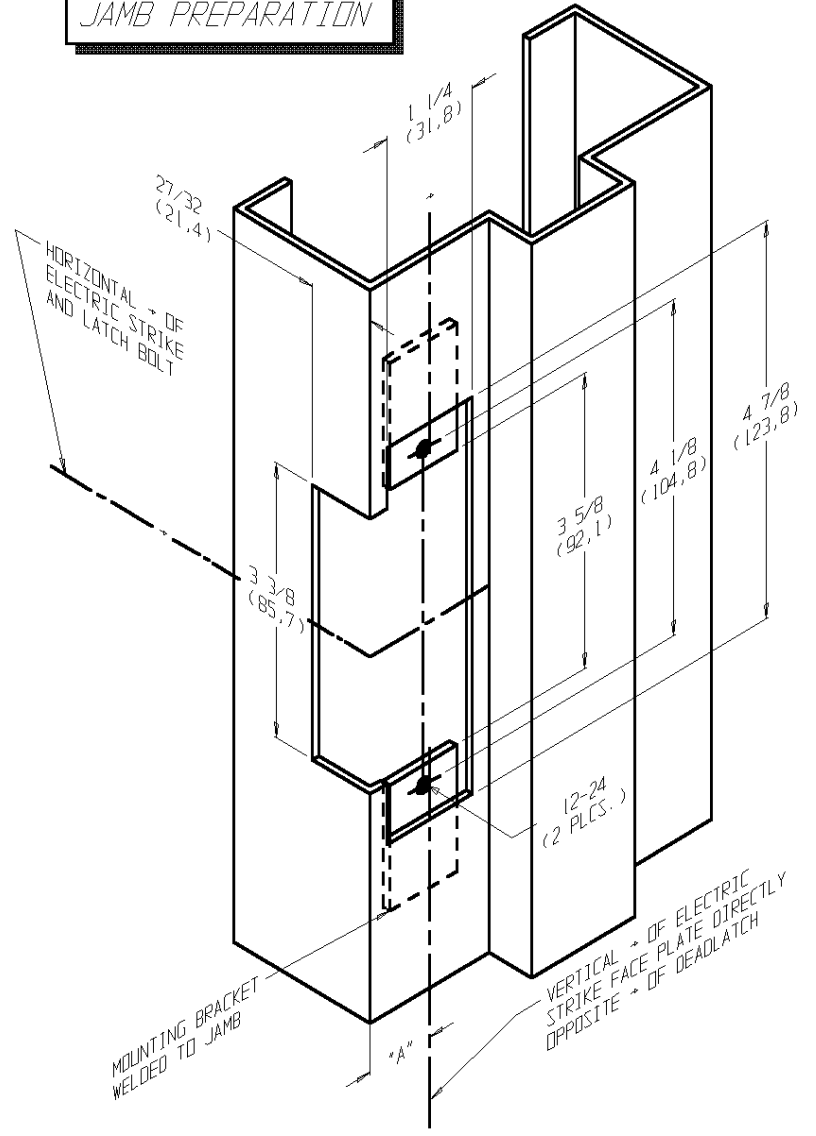

- NOTE:
1. WHEN DOOR SILENCERS ARE USED ON FRAMES, ADJUST STRIKE LOCATION TO ENSURE COMMON LATCH AND STRIKE CENTERLINES.
 2. STANDARD UNIT FITS DIM. "A" UP TO 1 1/16" (SEE DASH NO.)
 3. 7270-UL10B, 3HRS - FAIL SECURE ONLY.



FOR EXTENDED LIP: (DIM "A" DOOR → TO JAMB EDGE)

DASH NO.	DIM "A"	DASH NO.	DIM "A"	DASH NO.	DIM "A"
NONE	1.06	-05	2.00	-10	2.63
-01	1.50	-06	2.13	-11	2.75
-02	1.63	-07	2.25	-12	2.88
-03	1.75	-08	2.38	-13	3.00
-04	1.88	-09	2.50		