

Product Components

- ① 7500 Series Electric Strike Body
- ② #12-24 x 1/2" Mounting Screws
- ③ #12 x 2-1/2" Wood Screw (7505 only)
- ④ Keeper Shims
- ⑤ #4-40 x 1/2" Keeper Shim Screws
- ⑥ Trim Enhancer
- ⑦ #4-40 x 1/4" Trim Enhancer Screws
- ⑧ Plug In Connector

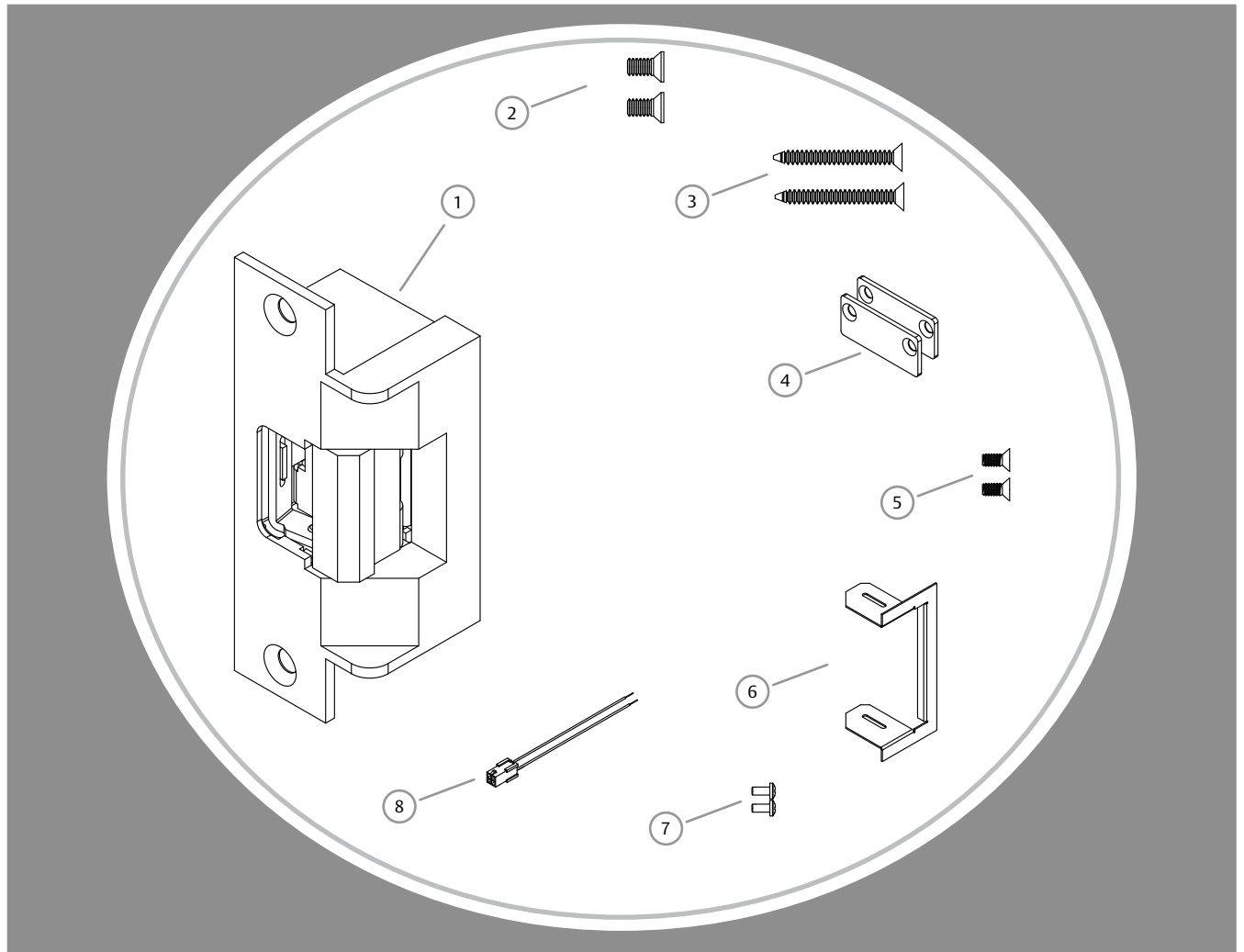

Electrical Specifications

ELECTRICAL RATINGS FOR SOLENOID		
CONTINUOUS DUTY	12VDC	24VDC
Resistance in Ohms	26.7	96
Amps	.45	.25
Solenoids are rated at +/- 10% indicated value.		

MINIMUM WIRE GAUGE REQUIREMENTS		
SOLENOID VOLTAGE	12VDC	24VDC
200 feet or less	18 gauge	20 gauge
200 - 300 feet	16 gauge	18 gauge
300 - 400 feet	14 gauge	16 gauge

Installation Directions

CAUTION! Before connecting any device at the installation site, verify input voltage using a multimeter. Many power supplies and low voltage transformers operate at higher levels than listed. Any input voltage exceeding 10% of the solenoid rating may cause severe damage to the unit and will void the warranty.

Prepare Strike

CAUTION: The 7500 series strike body ships as either a 12 or 24 volt unit, and is not field selectable. Verify that the power supply matches the voltage of the strike.

1. Make certain that the electric strike is in correct mode of operation for your application. This electric strike ships in fail secure mode. If you need to convert the unit to fail safe, see Diagram 1.
2. If using Latchbolt Monitor (LBM), see Diagram 2.

Prepare Frame

3. Prepare door jamb per the appropriate template detail on Page 3.

Finish Installing

4. Connect the Plug In Connector to the electric strike, and connect wires from the Plug In Connector leads to the power source.
5. Install the electric strike in the jamb cutout using the #12-24 x 1/2" mounting screws for metal applications, or the #12 x 2-1/2" wood screws for wood applications.
6. If horizontal adjustment is needed, keeper shims can be added as illustrated in Diagram 3, Page 4. The backset of the 7505 strike can be changed as illustrated in Diagram 5, page 4.
7. If necessary, the Trim Enhancer can be installed as illustrated in Diagram 4, Page 4.

DIAGRAM 1: FAIL SAFE CONVERSION

1. Remove the cotter pin from the solenoid linkage.
2. Remove the solenoid mounting screw and washers.
3. Remove the Solenoid from the keeper module.
4. Turn the solenoid upside down, and reinsert it back into the keeper module.
5. Re-install the mounting screw and washers at the opposite end of the keeper module. Make certain that the "D" washer is positioned firmly into the solenoid slot as noted on the illustration
6. Replace the cotter pin to secure the solenoid linkage.

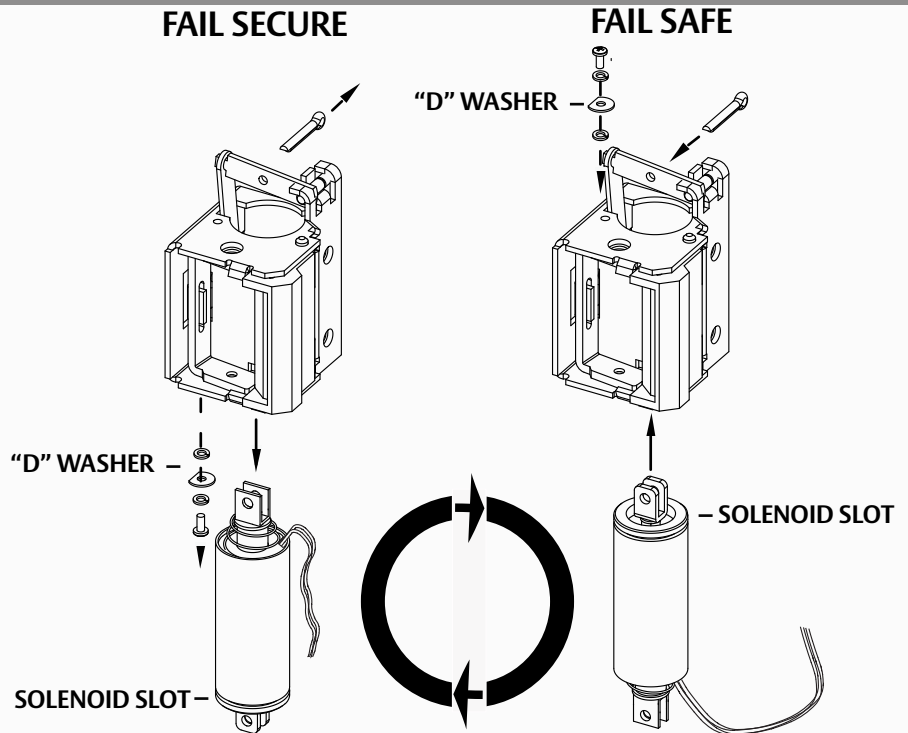
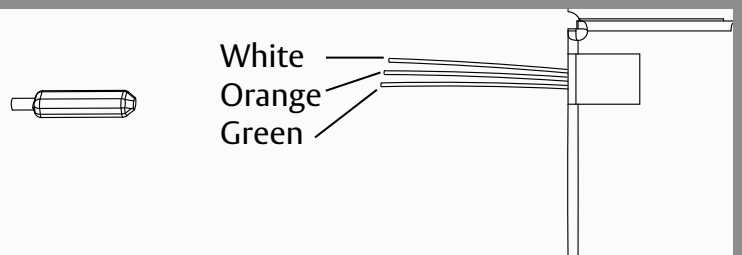
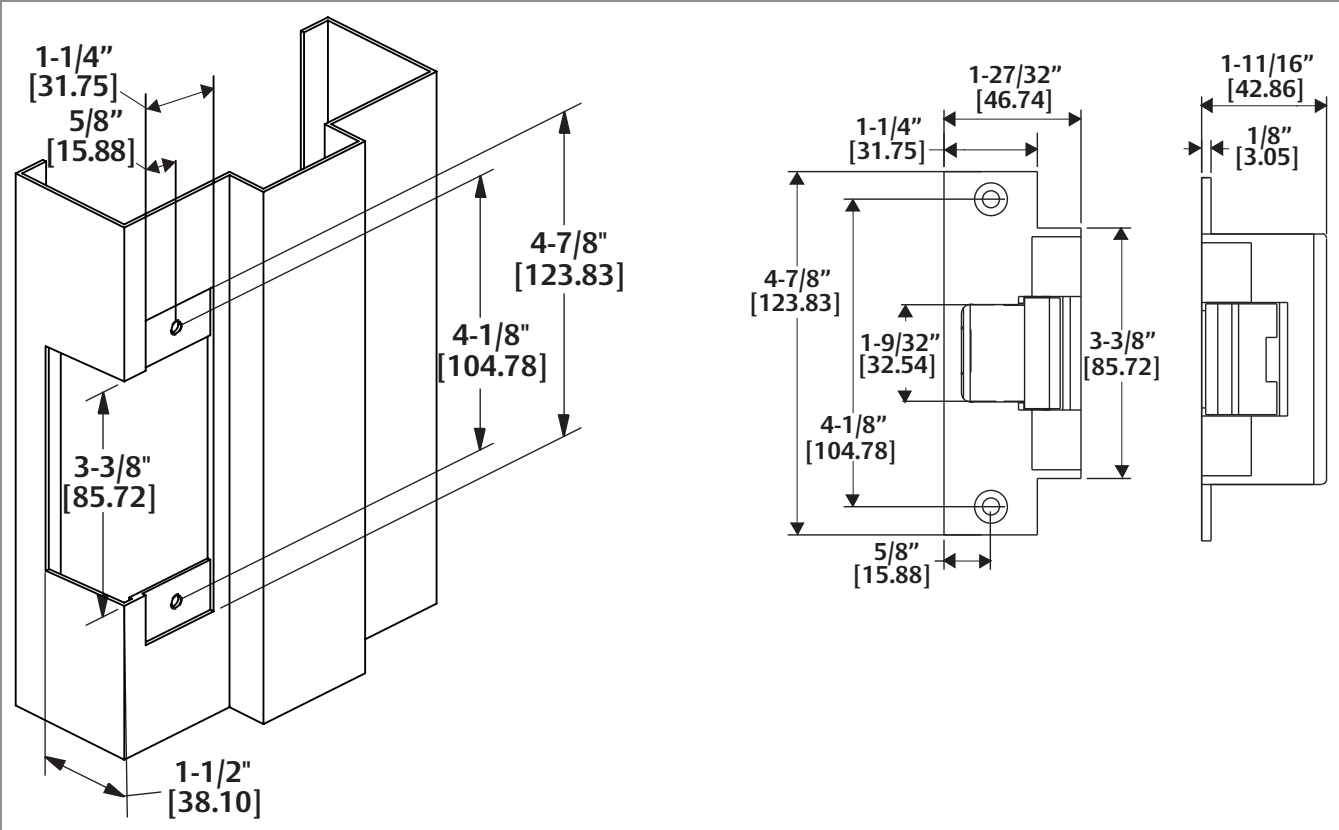

DIAGRAM 2: LBM WIRING

LBM WIRING	
White	Common
Orange	Normally Open
Green	Normally Closed



7501 Template & Dimensions



7505 Template & Dimensions

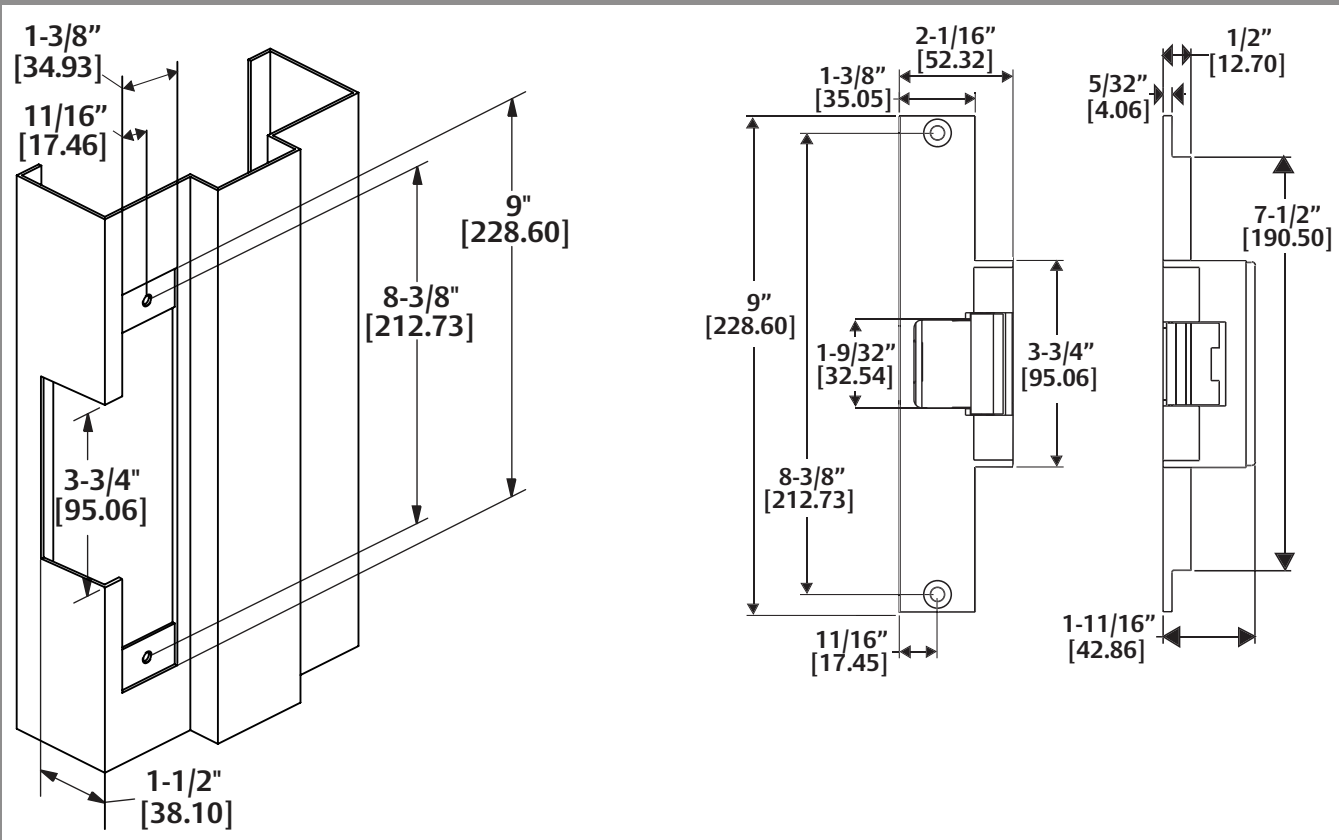

DIAGRAM 3: KEEPER SHIMS

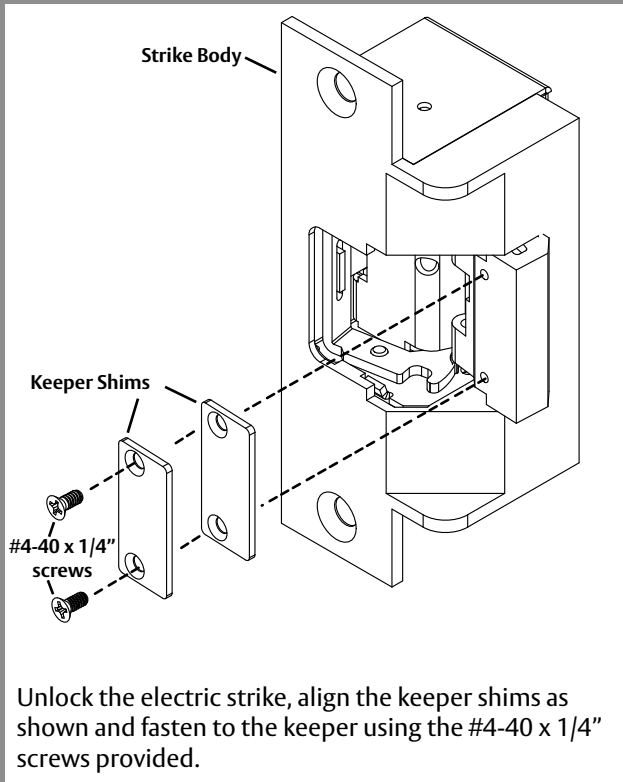

DIAGRAM 4: TRIM ENHANCER

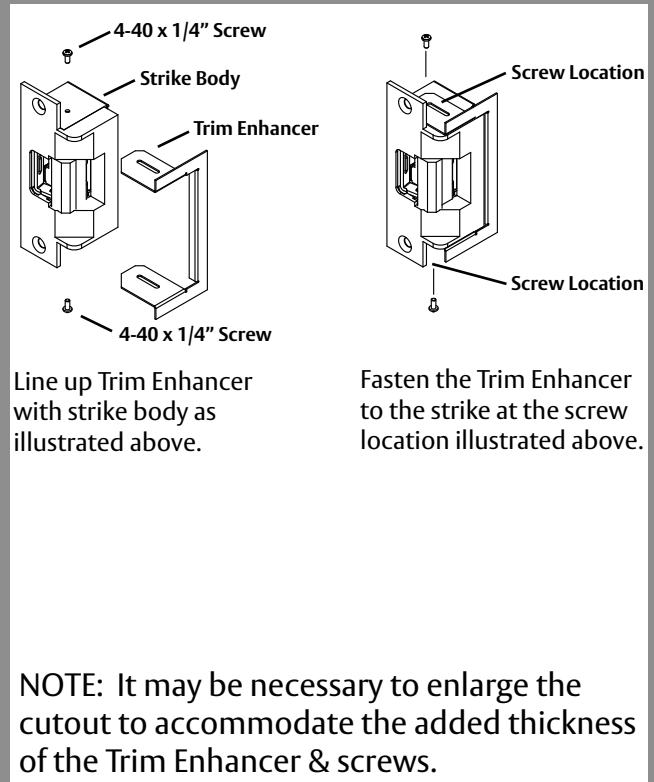
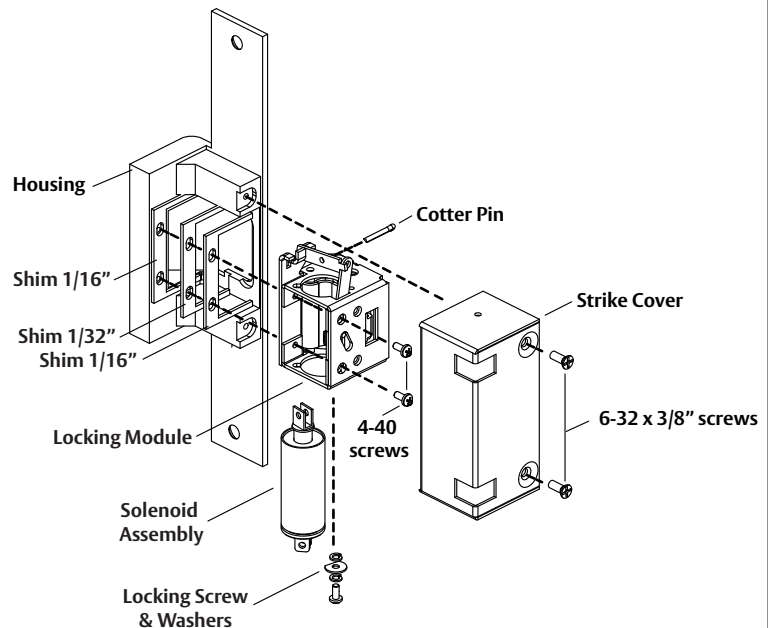

DIAGRAM 5: BACKSET ADJUSTMENT

1. Remove Strike Cover by removing two 6-32 x 3/8" screws as illustrated
2. Remove Solenoid Assembly from Locking Module by removing Locking Screw, Washers and Cotter Pin as illustrated.
3. Remove Locking Module from Housing by removing two 4-40 screws. Retain all hardware
4. Add any combination of 1/16" and 1/32" thick Shims to provide the required backset distance. (See Backset Configuration Chart)
5. Re-assemble electric strike.

NOTE: Strike is shown with 5/32" backset.



Backset Configuration Chart			
Backset Distance	Quantity 1/32" Shim	Quantity 1/16" Shim	Screw Length
1/32"	1	NONE	3/8"
1/16"	NONE	1	3/8"
3/32"	1	1	3/8"
1/8"	NONE	2	3/8"
5/32"	1	2	1/2"